



zaffaroni
TECHNOLOGICAL SYSTEMS

BIM
Building Information Model

BIM

Building Information Model

BIM, a Building Information Model, is revolutionizing the way of defining and managing projects.

This is not a simply 3D design software, but rather a process that simplifies collaboration among different project teams. With BIM digital tools and high level technical services, you can access complete workflow solutions.

BIM IS MODIFYING ALL BUILDING'S SECTOR

With BIM, together with plant design, is possible to:

- Reduce errors and costs
- Find potential 2D and 3D interferences for extremely accurate projects.
- Improve collaboration in the cloud
- Facilitate teamwork and prevent mistakes by sharing projects in real time.

*General view of electric and mechanical plants of Torre Hadid
City Life, Milan*

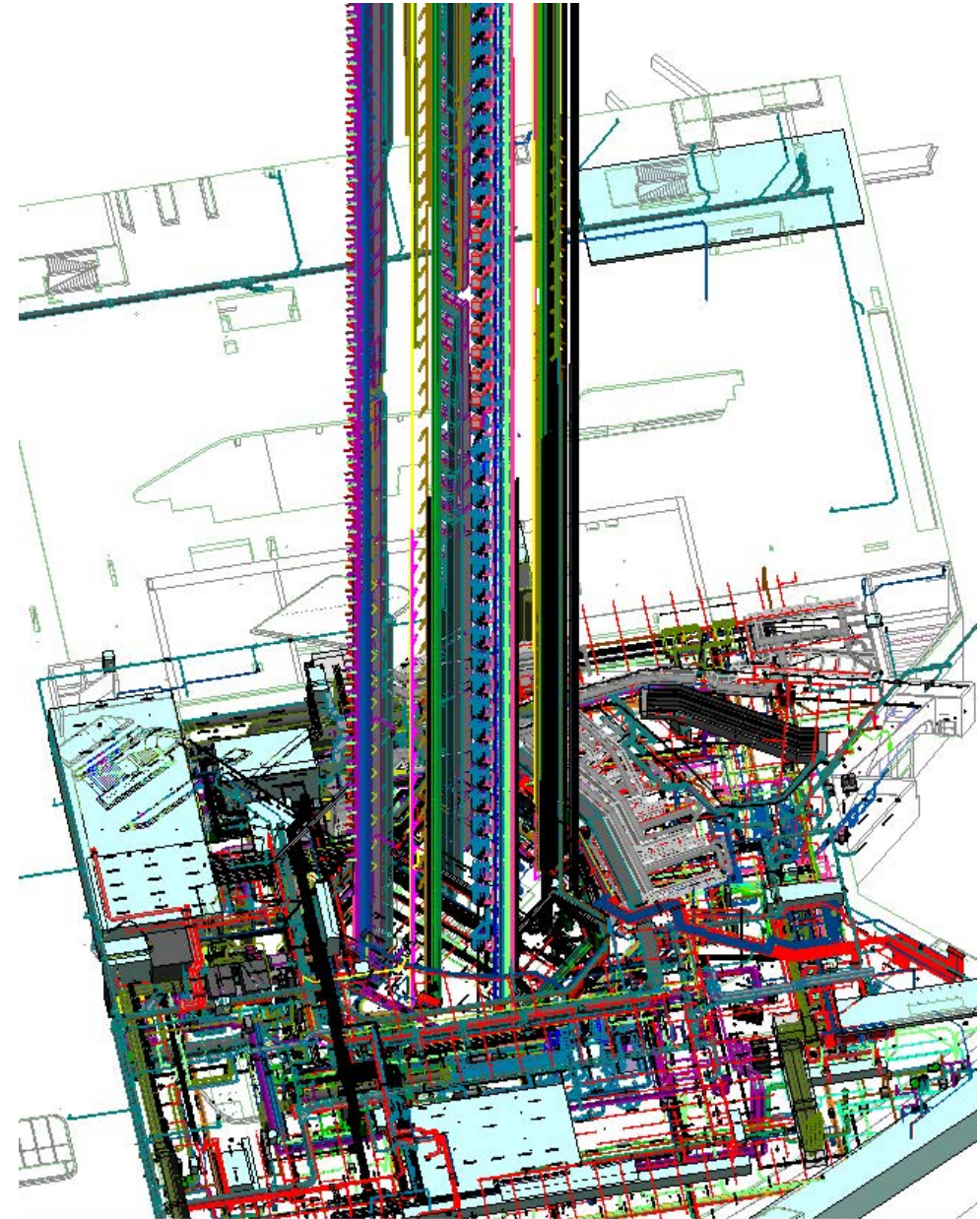

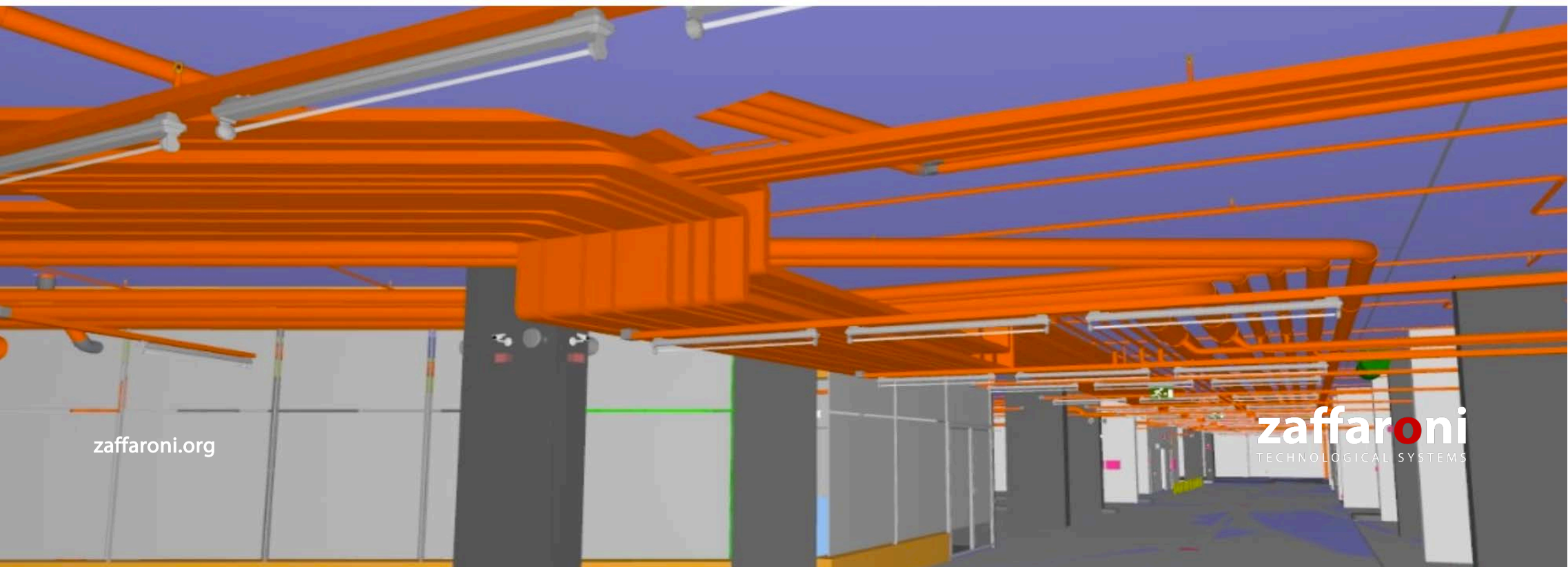
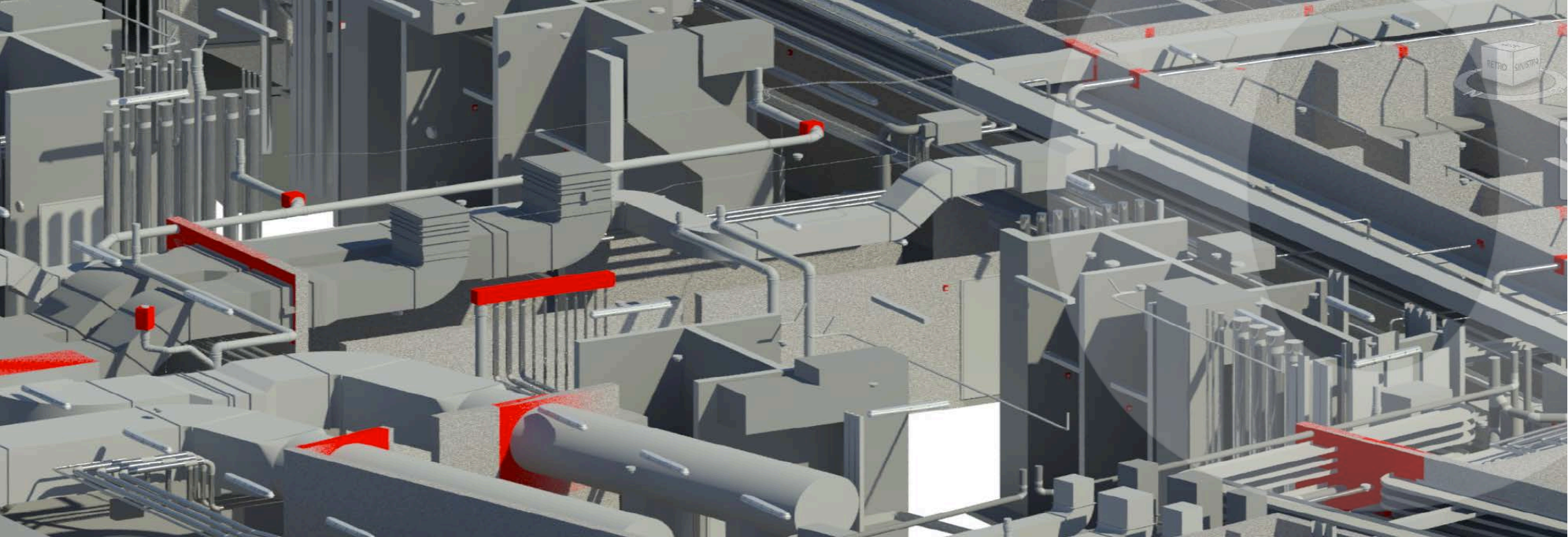

zaffaroni.org

zaffaroni
TECHNOLOGICAL SYSTEMS

BIM

Building Information Model

BIM is a "Building Information Container" which you can enter in graphic data (such as drawings) and specific technical attributes, for example related to the expected life cycle.

Designing objects such as walkways, pipes, terminals, paintings, or other equipment, additional information such as materials, technical data sheets, electrical absorption, etc. can be associated with the graphic information.

Unlike CAD design, which allows you to design a project through 2D or 3D drawings, MEP design is not limited to visual information or rendering, but it specifies the features and performance of each object present in the project.

BIM, born from desire to reach the collaboration between designers and the processes integration, is a collaborative design method as it allows to integrate the useful information at every stage of design: architectural, structural, plant engineering and management.

Torre Libeskind, City Life, Milan

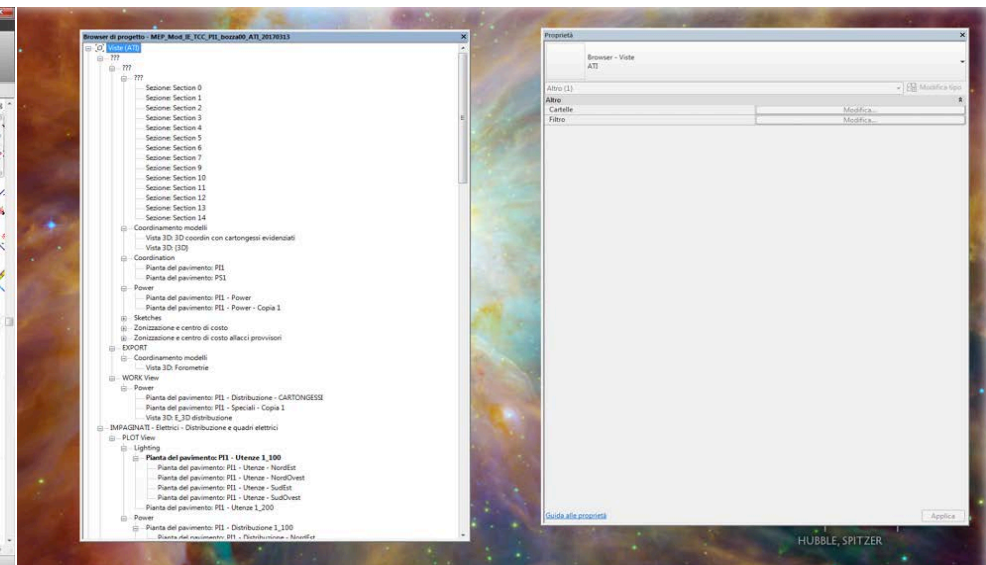
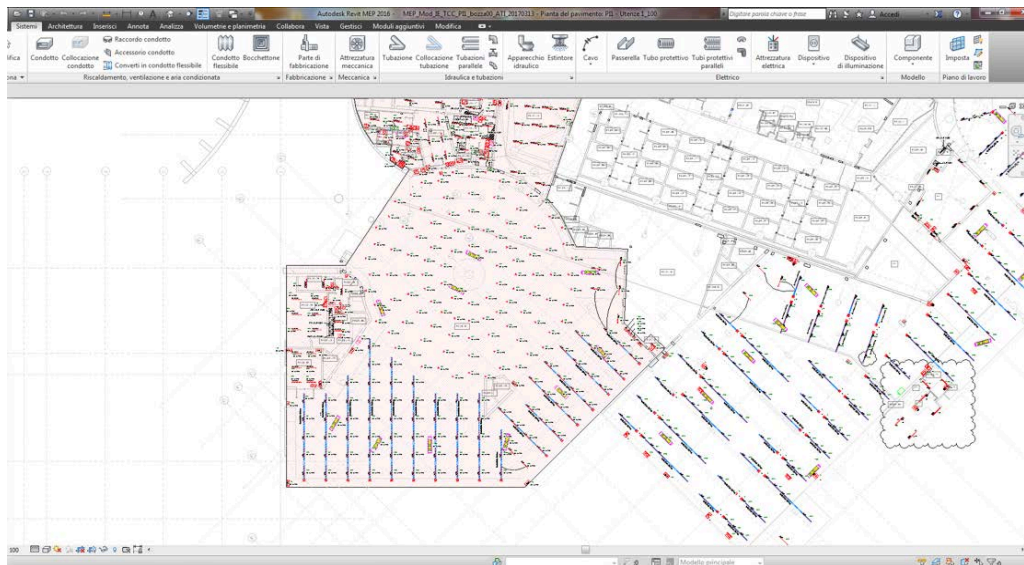

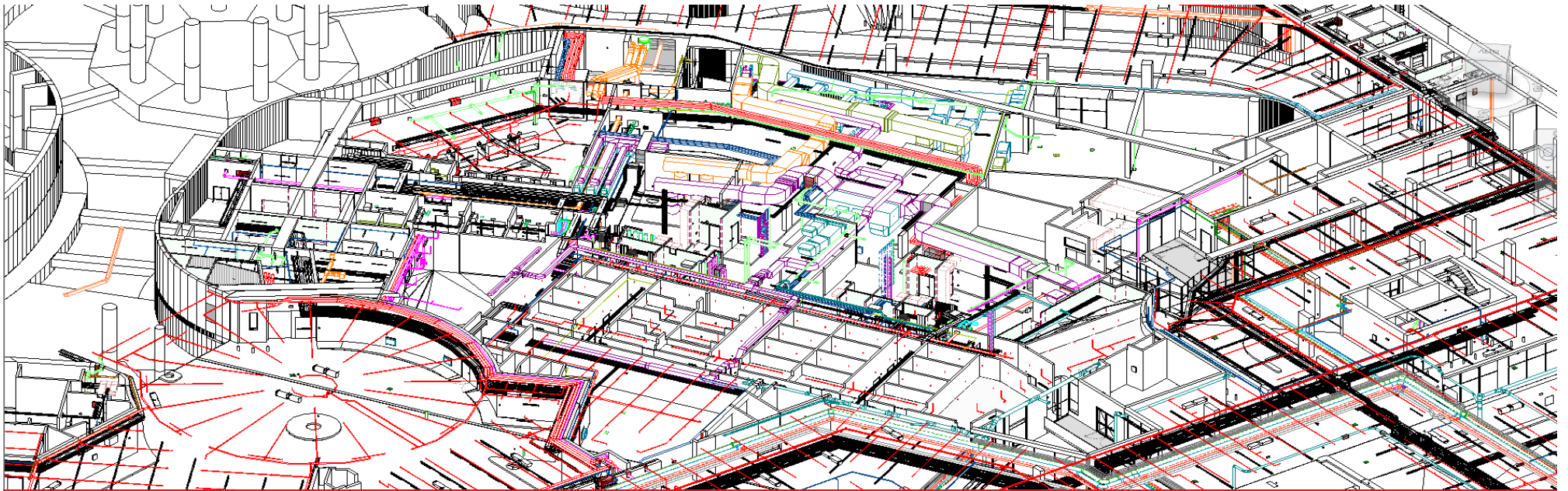

↑ Global View – plant “piastra” and viability

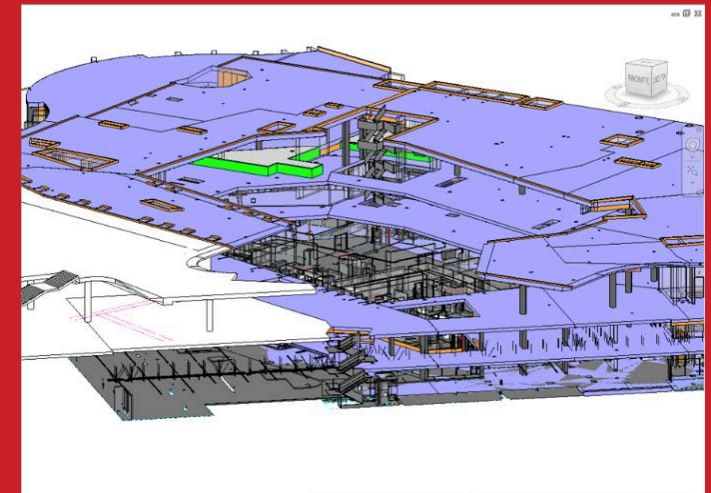
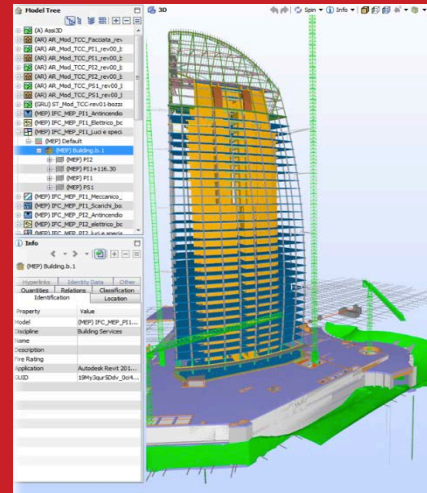
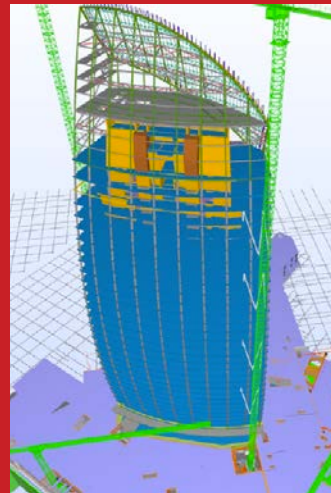

↑ Coordination model of Torre Libeskind, City Life, Milan

ELECTRICAL SYSTEMS

Design of electrical systems through BIM model is facilitated by the possibility of simultaneously managing different objects, depending on their planting nature.

In this regard, electric assemblies, coordinated with mechanical or hydraulic ones, which often clash by channel positions rather than traces under the wall, etc., can find a wide application.

Electrical design, is studied from the beginning, to model:

- electrical appliances
- electrical equipment
- lighting devices
- Data devices, telephone, safety and control circuits, alarm devices, etc.

With the implementation of BIM, it is possible to design electrical systems of all kinds and to provide a specific service for the coordination of these and their distribution lines (pipes, protective pipes, pipes and junctions) to a construction level of detail in order to overcome any conflict with other MEP disciplines with the aim of explicating any incongruity or interference with the site.

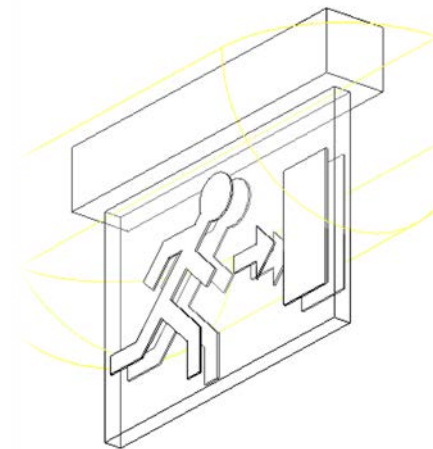
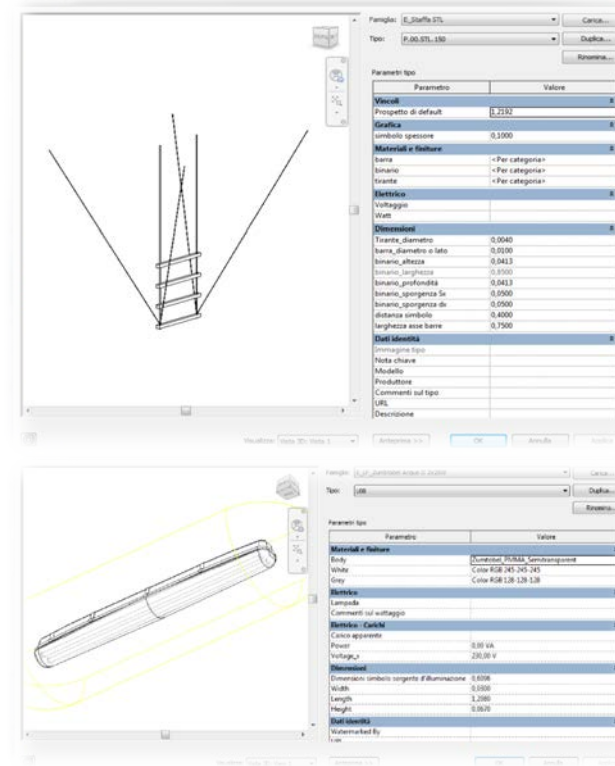

Examples of parameterization of the electrical system objects, City Life, Milan

zaffaroni
TECHNOLOGICAL SYSTEMS

F.Ili Zaffaroni S.r.l.

info@zaffaroni.org
www.zaffaroni.org

Via Milano, 17
21040 Jerago con Orago (VA) - Italia
Tel. +39 0331 215090
Fax: +39 0331 213021

Corso Allamano, 141
10098 Rivoli (TO) - Italia
Tel. +39 0331 215090
Fax: +39 0331 213021

Chemin de Prédérès, 3
1276 Gingins - Suisse
Tel.+41 (0)22 3690050
Fax: +41 (0)22 3690600